

**evolution**

[www.evolutionbuild.com](http://www.evolutionbuild.com)



**EC - DECLARATION OF CONFORMITY**

**We, Evolution Power Tools Limited, Venture One, Longacre Close, Sheffield, S20 3FR as the supplier of the product listed below:**

EVOLUTION 305mm (12")  
Multipurpose Electric Disc Cutter

Voltage 110V/230V  
Power 2400W

**Declare, under our sole responsibility that the equipment to which this document relates, is in conformity with the following standards or other normative documents:**

EN55014-1: 2006  
EN55014-2: 1997+A1  
EN61000-3-2: 2006  
EN61000-3-3: 1995+A1+A2  
EN60745-1: M2006  
EN60745-2-5: 2007

And thereby conforms to the protection requirements of Council Directive **2006/95/EC** relating to the Low Voltage Directive, Council Directive **98/37/EEC** relating to the Machine Directive and Council Directive **2004/108/EC** relating to the EMC Directive, and is compliant with Council Directive **2002/95/EC** in relation to the Restriction of Hazardous Substances in electrical & electronic equipment (RoHS). EU Directive **2002/95/EC** restricts the use of the 6 substances following in the manufacture of specific types of electrical equipment. Whilst this restriction does not legally apply to components, it is recognized that component 'compliance' is relevant to many customers.

**Evolution Power Tools definition of RoHS Compliance:**

- The product does not contain any restricted substances in concentrations and applications banned by the directive and for components, the product is capable of being worked at the higher temperatures required by lead-free soldering.
- The restricted substances and maximum allowed concentrations in homogenous materials are, by weight:

**Lead - 0.1%**

**Mercury - 0.1%**

**PBB (Polybrominated Biphenyls) - 0.1%**

**PBDE (Polybrominated Diphenyl Ethers) - 0.1%**

**Hexavalent Chromium - 0.1%**

**Cadmium - 0.01%**

Level of Sound pressure according to  
**86/188/EEC & 98/37/EC**

**Guaranteed Sound Power Level 98.8 dB(A)**

All relevant technical documentation is held at Evolution Power Tools Ltd, Sheffield, United Kingdom.

Authorised By



**Mr Matthew J Gavins**  
Managing Director

2nd March 2009



# DISC CUTTER

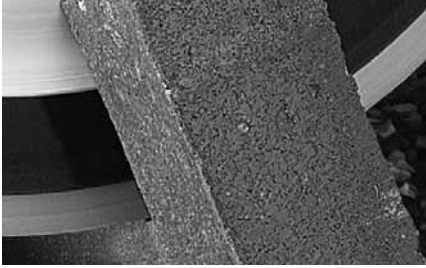

<b>GB</b>	05
-----------	----

<b>NL</b>	00
-----------	----

<b>FR</b>	00
-----------	----

<b>DE</b>	00
-----------	----

<b>GR</b>	00
-----------	----

<b>IT</b>	00
-----------	----

<b>PT</b>	00
-----------	----

<b>ES</b>	00
-----------	----

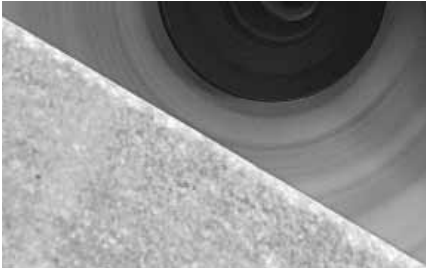

**GB**

# Instruction Manual

Read instructions before operating this tool.

**IMPORTANT****GB**

Please read these operating and safety instructions carefully and completely. For your own safety, before using this equipment check that the voltage is correct and that all handles and parts are firmly secured. If you are uncertain about any aspect of using this equipment, please contact our Technical Helpline.

**Technical Helpline UK****0870 609 2297****Technical Helpline USA****1-866-EVO-TOOL****Evolution 305mm (12") Electric Disc Cutter**

Congratulations on your purchase of an Evolution Power Tools Circular Saw. Please complete and mail your product registration card or register on line to validate your machine's warranty period and ensure prompt service if needed. We sincerely thank you for selecting a product from Evolution Power Tools.

**12 MONTH LIMITED WARRANTY.** EVOLUTION POWER TOOLS RESERVES THE RIGHT TO MAKE IMPROVEMENTS AND MODIFICATIONS TO DESIGN WITHOUT PRIOR NOTICE.

Evolution Power Tools will, within twelve (12) months from the original date of purchase, repair or replace any goods found to be defective in materials or workmanship, provided the product warranty registration card has been returned to Evolution Power Tools. This warranty is void if the tool being returned has been used to cut materials beyond the recommendations in the Instruction Manual or if the saw has been damaged by accident, neglect, or improper service. This warranty does not apply to machines and / or components which have been altered, changed, or modified in any way, or subjected to use beyond recommended capacities and specifications. Electrical components are subject to respective manufacturers' warranties. All goods returned defective shall be returned prepaid freight to Evolution Power Tools. Evolution Power Tools reserves the right to optionally repair or replace it with the same or equivalent item. There is no warranty – written or verbal – for saw blades. In no event shall Evolution Power Tools be liable for loss or damage resulting directly or indirectly from the use or merchandise or from any other cause. Evolution Power Tools is not liable for any costs incurred on such goods or consequential damages. No officer, employee or agent of Evolution Power Tools is authorised to make oral representations of fitness or to waive any of the foregoing terms of sale and none shall be binding on Evolution Power Tools.

Questions relating to this limited warranty should be directed to the company's head office, or call the appropriate Helpline number.

## GENERAL SAFETY RULES

GB

**WARNING!** READ AND UNDERSTAND ALL INSTRUCTIONS BEFORE OPERATING THIS PRODUCT. FAILURE TO FOLLOW ALL INSTRUCTIONS LISTED BELOW, MAY RESULT IN ELECTRIC SHOCK, FIRE AND / OR SERIOUS PERSONAL INJURY.

### SAVE THESE INSTRUCTION FOR FUTURE REFERENCE.

**WARNING!** WHEN USING ELECTRIC TOOLS BASIC SAFETY PRECAUTIONS SHOULD ALWAYS BE FOLLOWED TO REDUCE THE RISK OF FIRE, ELECTRIC SHOCK AND PERSONAL INJURY INCLUDING THE FOLLOWING.

Read all these instructions before attempting to operate this product and save these instructions.

The term "power tool" in the warnings refers to your mains-operated (corded) power tool or battery-operated (cordless) power tool.

#### 1) Work Area Safety

- a)** Keep work area clean and well lit. Cluttered or dark areas invite accidents.
- b)** Do not operate power tools in explosive atmospheres, such as in the presence of flammable liquids, gases or dust. Power tools create sparks which may ignite the dust or fumes.
- c)** Keep children and bystanders away while operating a power tool. Distractions can cause you to lose control.

#### 2) Electrical Safety

- a)** Power tool plugs must match the outlet. Never modify the plug in any way. Do not use any adapter plugs with earthed (grounded) power tools. Unmodified plugs and matching outlets will reduce risk of electric shock.
- b)** Avoid body contact with earthed or grounded surfaces, such as pipes, radiators, ranges and refrigerators. There is an increased risk of electric shock if your body is earthed or grounded.
- c)** Do not expose power tools to rain or wet conditions. Water entering a power tool will increase the risk of electric shock.
- d)** Do not abuse the cord. Never use the cord for carrying, pulling or unplugging the power tool. Keep cord away from heat, oil, sharp edges or moving parts. Damaged or entangled cords increase the risk of electric shock.
- e)** When operating a power tool outdoors, use an extension cord suitable for outdoor use. Use of a cord suitable for outdoor use reduces the risk of electric shock.
- f)** If operating a power tool in a damp location is unavoidable, use a residual current device (RCD) protected supply. Use of an RCD reduces the risk of electric shock.

#### 3) Personal Safety

- a)** Stay alert, watch what you are doing and use common sense when operating a power tool. Do not use a power tool while you are tired or under the influence of drugs, alcohol or medication. A moment of inattention while operating power tools may result in serious personal injury.
- b)** Use personal protective equipment. Always wear eye protection. Protective equipment such as dust mask, non-skid safety shoes, hard hat, or hearing protection used for appropriate conditions will reduce personal injuries.
- c)** Prevent unintentional starting. Ensure the switch is in the off-position before connecting to power source and/or battery pack, picking up or carrying the tool. Carrying power tools with your finger on the switch or energising power tools that have the switch on invites accidents.
- d)** Remove any adjusting key or wrench before turning the power tool on. A wrench or a key left attached to a rotating part of the power tool may result in personal injury.
- e)** Do not overreach. Keep proper footing and balance at all times. This enables better control of the power tool in unexpected situations.
- f)** Dress properly. Do not wear loose clothing or jewellery. Keep your hair, clothing and gloves away from moving parts. Loose clothes, jewellery or long hair can be caught in moving parts.
- g)** If devices are provided for the connection of dust extraction and collection facilities, ensure these are connected and properly used. Use of dust collection can reduce dust-related hazards.

#### 4) Power Tool Use & Care

- a)** Do not force the power tool. Use the correct power tool for your application. The correct power tool will do the job better and safer at the rate for which it was designed.
- b)** Do not use the power tool if the switch does not turn it on and off. Any power tool that cannot be controlled with the switch is dangerous and must be repaired.
- c)** Disconnect the plug from the power source and/or the battery pack from the power tool before making any adjustments, changing accessories, or storing power tools. Such preventive safety measures reduce the risk of starting the power tool accidentally.
- d)** Store idle power tools out of the reach of children and do not allow persons unfamiliar with the power tool or these instructions to operate the power tool. Power tools are dangerous in the hands of untrained users.
- e)** Maintain power tools. Check for misalignment or binding of moving parts, breakage of parts and any other condition that may affect the power tool's operation. If damaged, have the power tool repaired before use. Many accidents are caused by poorly maintained power tools.
- f)** Keep cutting tools sharp and clean. Properly maintained cutting tools with sharp cutting edges are less likely to bind and are easier to control.

**g)** Use the power tool, accessories and tool bits etc. in accordance with these instructions, taking into account the working conditions and the work to be performed. Use of the power tool for operations different from those intended could result in a hazardous situation.

**5) Service**

**a)** Have your tool repaired by a qualified person. This electric tool complies with the relevant safety rules. Repairs should only be carried out by qualified persons using original spare parts, otherwise this may result in considerable danger to the user.

**b)** When servicing a tool, use only genuine Evolution replacement parts. Follow instructions in the Maintenance section of this manual. Use of unauthorized parts or failure to follow Maintenance Instructions may create a risk of electric shock or injury.

**SPECIFIC SAFETY RULES & SYMBOLS** GB

**WARNING!** DO NOT OPERATE MACHINE IF WARNING AND / OR INSTRUCTION LABELS ARE MISSING OR DAMAGED. CONTACT EVOLUTION POWER TOOLS FOR REPLACEMENT LABELS.

Symbol	Description
V	Volts
A	Amperes
Hz	Hertz
Min	Minutes
~	Alternating current
No	no load speed
	Double Insulated

Only use genuine Evolution replacement blades. Unauthorized blades may be dangerous! Keep saw blades securely fastened. Check blade flanges for debris before installing any new blade. Do not use dull or broken blades. Check blades often for condition and wear. Damaged or worn blades should be replaced immediately. Check chip collector cover for proper fit to minimize the risk of flying debris. Loose fitting or damaged collector must be replaced immediately. Beware of ejecting chips as they may be HOT. Always make provisions for safe handling of excess material. Keep bottom of base plate free from dirt and other debris.

To obtain an additional copy of your manual, please contact Evolution Power Tools at:

**UK** **0870 609 2297**  
**USA** **1-866-EVO-TOOL**  
**Web** **www.evolutionpowertools.com**

**ADDITIONAL SPECIFIC SAFETY RULES**

**a) DANGER:** Keep hands away from cutting area and the blade. Keep your second hand on auxiliary handle, or motor housing. If both hands are holding the saw, they cannot be cut by the blade.

**b)** Do not reach underneath the workpiece. The guard cannot protect you from the blade below the workpiece.

**c)** Adjust the cutting depth to the thickness of the workpiece. Less than a full tooth of the blade teeth should be visible below the workpiece.

**d)** Never hold piece being cut in your hands or across your leg. Secure the workpiece to a stable platform. It is important to support the work properly to minimize body exposure, blade binding, or loss of control.

**e)** Hold power tool by insulated gripping surfaces when performing an operation where the cutting tool may contact hidden wiring or its own cord. Contact with a "live" wire will also make exposed metal parts of the power tool "live" and shock the operator.

**f)** When ripping always use a rip fence or straight edge guide. This improves the accuracy of cut and reduces the chance of blade binding.

**g)** Always use blades with correct size and shape (diamond versus round) of arbour holes. Blades that do not match the mounting hardware of the saw will run eccentrically, causing loss of control.

**h)** Never use damaged or incorrect blade washers or bolt. The blade washers and bolt were specially designed for your saw, for optimum performance and safety of operation.

**FURTHER SAFETY INSTRUCTIONS FOR ALL SAWS**

**CAUSES AND OPERATOR PREVENTION OF KICKBACK:**

- kickback is a sudden reaction to a pinched, bound or misaligned saw blade, causing an uncontrolled saw to lift up and out of the workpiece toward the operator;
- when the blade is pinched or bound tightly by the kerf closing down, the blade stalls and the motor reaction drives the unit rapidly back toward the operator;
- if the blade becomes twisted or misaligned in the cut, the teeth at the back edge of the blade can dig into the top surface of the wood causing the blade to climb out of the kerf and jump back toward the operator.

KICKBACK IS THE RESULT OF SAW MISUSE AND/OR INCORRECT OPERATING PROCEDURES OR CONDITIONS AND CAN BE AVOIDED BY TAKING PROPER PRECAUTIONS AS GIVEN BELOW.

**a)** Maintain a firm grip with both hands on the saw and position your arms to resist kickback forces. Position your body to either side of the blade, but not in line with the blade. Kickback could cause the saw to jump backwards, but kickback forces can be controlled by the operator, if proper precautions are taken.

**b)** When blade is binding, or when interrupting a cut for any reason, release the trigger and hold the saw motionless in the material until the blade comes to a complete stop. Never attempt to remove the saw from the work or pull the saw backward while the blade is in motion or kickback may occur. Investigate and take corrective actions to eliminate the cause of blade binding.

**c)** When restarting a saw in the workpiece, centre the saw blade in the kerf and check that saw teeth are not engaged into the material. If saw blade is binding, it may walk up or kickback from the workpiece as the saw is restarted.

**d)** Support large panels to minimise the risk of blade pinching and kickback. Large panels tend to sag under their own weight. Supports must be placed under the panel on both sides, near the line of cut and near the edge of the panel.

**e)** Do not use dull or damaged blades. Unsharpened or improperly set blades produce narrow kerf causing excessive friction, blade binding and kickback.

**f)** Blade depth and bevel adjusting locking levers must be tight and secure before making cut. If blade adjustment shifts while cutting, it may cause binding and kickback.

**g)** Use extra caution when making a “plunge cut” into existing walls or other blind areas. The protruding blade may cut objects that can cause kickback.

**d)** Always observe that the lower guard is covering the blade before placing saw down on bench or floor. An unprotected, coasting blade will cause the saw to walk backwards, cutting whatever is in its path. Be aware of the time it takes for the blade to stop after switch is released.

**CAUTION!** ALWAYS UNPLUG SAW BEFORE CHANGING BLADES, SERVICING, CLEANING OR ADJUSTING THE SAW.

## FURTHER SAFETY INSTRUCTIONS FOR ALL SAWS GB

### SPECIFICATIONS

#### Model ELECTRIC DISC CUTTER Specifications

Motor (230V 50/60 Hz) (Watts)	2400W
Maximum Cutting Depth	4" / 100mm
Speed	5000min <sup>-1</sup>
Weight	9.5kg

#### Blade Dimensions

Maximum Diameter	12" / 305mm
Bore Diameter	22mm
Thickness	1/16" / 2mm

### SAFETY INSTRUCTIONS FOR SAWS

**a)** Check lower guard for proper closing before each use. Do not operate the saw if lower guard does not move freely and close instantly. Never clamp or tie the lower guard into the open position. If saw is accidentally dropped, lower guard may be bent. Raise the lower guard with the retracting handle and make sure it moves freely and does not touch the blade or any other part, in all angles and depths of cut.

**b)** Check the operation of the lower guard spring. If the guard and the spring are not operating properly, they must be serviced before use. Lower guard may operate sluggishly due to damaged parts, gummy deposits, or a build-up of debris.

**c)** Lower guard may be retracted manually only for special cuts such as “plunge cuts” and “compound cuts.” Raise lower guard by retracting handle and as soon as blade enters the material, the lower guard must be released. For all other sawing, the lower guard should operate automatically.

**SYMBOL KEY**

GB



Check.



Read instruction manual.



Wear safety goggles.



Wear ear protectors.



Needs servicing.



Wear dust mask.



Wear gloves.



Wear safety boots.

**SAFETY INSTRUCTIONS**

GB

WARNING! When using electric power tools basic safety precautions should always be followed to reduce the risk of fire, electric shock and personal injury. When not in use, tools should be stored in a dry, locked up place, out of reach of children.





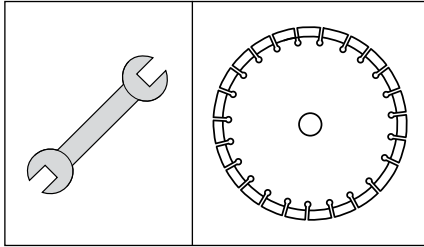

## ACCESSORIES

GB

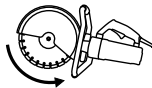

## TECHNICAL DATA

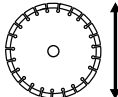
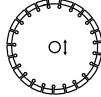
GB

	110 - 230 V 2400 W		99dB(A)
	5000min <sup>-1</sup>		20 mins
	305mm		22.2 / 20mm
	2.0mm		9.5Kg

QUICK START GUIDE

GB

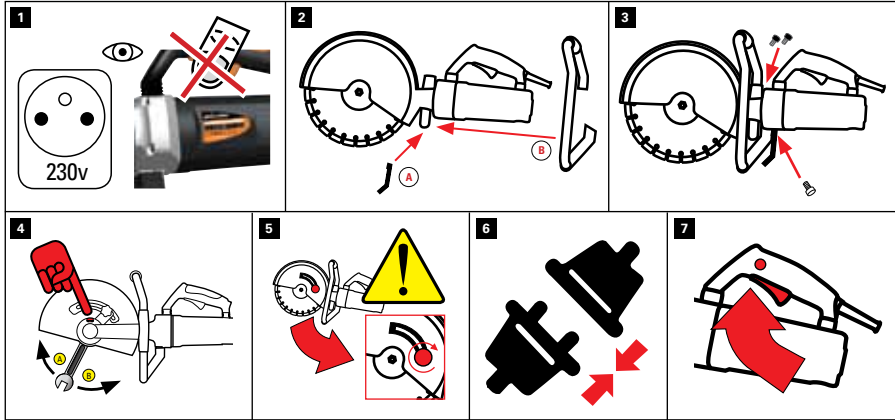

CHANGING BLADE

GB

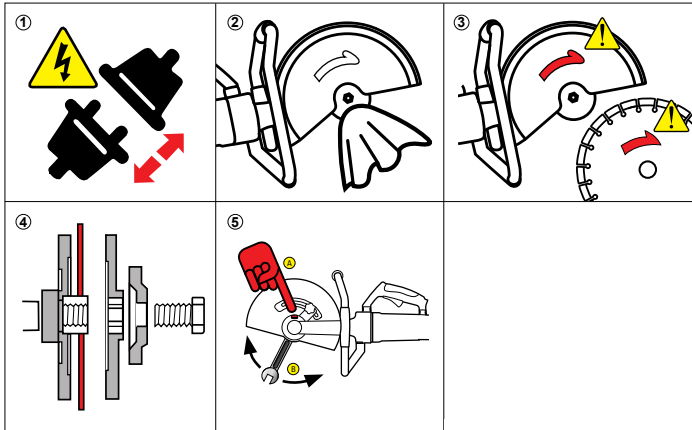

## MAINTENANCE & INSPECTION

Inspecting the carbon brushes. Replacing a carbon brush.

GB

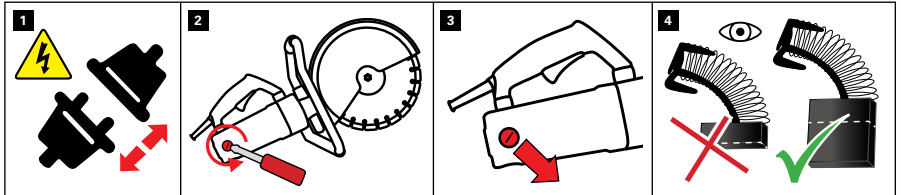

## INSTALLING THE DUST HOSE

Do not use dust collection hose when cutting metal.

GB

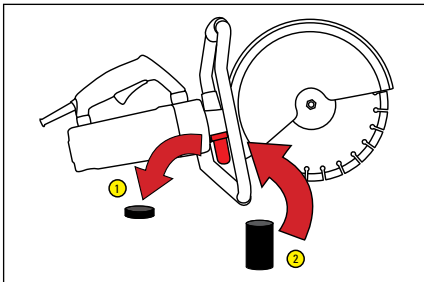

If dust hose not in use cap must be replaced!

**MACHINE DETAILS**

GB

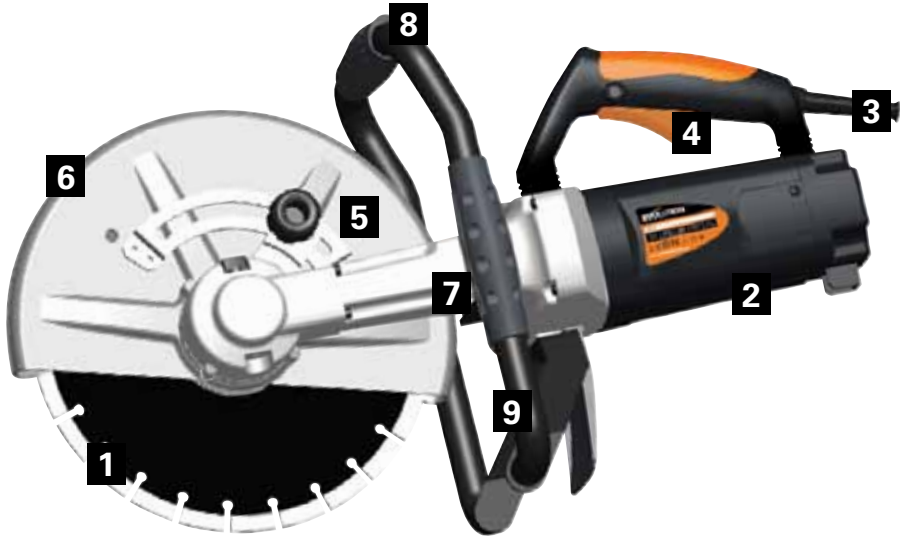

GB

- |                           |                    |
|---------------------------|--------------------|
| 1. Blade                  | 6. Blade Cover     |
| 2. Motor Housing          | 7. Dust Extractor  |
| 3. Cable                  | 8. Top Handle      |
| 4. Safety Trigger         | 9. Side Handle     |
| 5. Blade Cover Adjustment | 10. Safety Trigger |

**MACHINE DETAILS**

GB

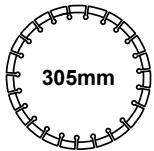

UK

- |                               |
|-------------------------------|
| Cutting or Scribing Concrete  |
| Cutting or Scribing Stone     |
| Cutting Steel                 |
| Cutting or Scribing Tile      |
| Cutting or Scribing Roof Tile |

## OPERATING INSTRUCTIONS

UK

